



## ŠVEC a SPOL speeds up deep-drawing automotive project with PAM-STAMP 2G

### THE CHALLENGE

After weeks of traditional trial and error approach on the most challenging deep-drawn automotive component ŠVEC a SPOL s.r.o. had ever worked on, they turned to PAM-STAMP 2G to find a viable solution and to make up for the lost time.

### THE BENEFITS

- Development time reduced from 14 to 4 months,
- Fast computation allowing multiple scenarios,
- Reliable results,
- Tailor-made training provided,
- No prototype tools produced.

*"With its decision to implement PAM-STAMP 2G, ŠVEC a SPOL s.r.o. was able to rank among the most successful tool producers. We considerably increased our quality standards and gained new experience that helped us to attract new customers and new orders."*

Lúbovím ŠVEC,  
Owner and General Manager  
of ŠVEC a SPOL, s.r.o.

In 2003, ŠVEC a SPOL s.r.o. earned an order for the production of tools for a wheelhouse for a ŠKODA automotive component.

From the start the company was well aware that in terms of shape, and especially draw depth, this would be the most complicated part they had ever produced. Nevertheless they decided to work on this order using the traditional trial and error method.

For several weeks, ŠVEC a SPOL s.r.o. tested different variations of drawing operations performance and produced several prototype tools; however, they were not doing well. They were not able to produce a part without a crack, an unacceptable corrugation or some folds of material. The company understood that this method would not allow them to fulfill their customer's order in accordance with all requirements and conditions. Therefore, they decided to integrate simulation into their development process.

*"...This order was, right from the very beginning, processed with PAM-STAMP 2G, no prototype tools were produced..."*

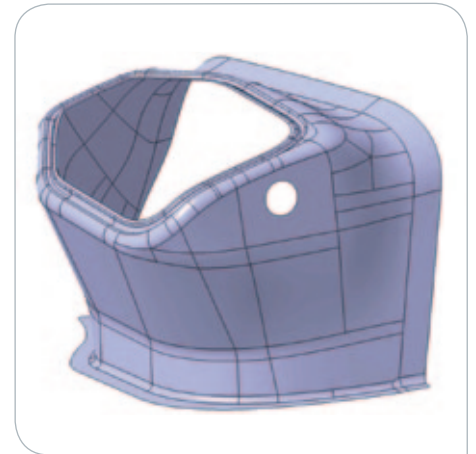

ŠKODA automotive component  
wheelhouse

ŠVEC a SPOL s.r.o. placed an order for the design of drawing operations simulation by an external company; however, this cooperation was not successful either. The simulation of one of their drafts took several weeks and all the results were wrong, showing ruptures and folds of material.

After all these failed attempts the company was very late and under high pressure, and turned to ESI Group. Local ESI experts in the Czech Republic were promptly available to help them solve their problems concerning the production of the wheelhouse component. They introduced ŠVEC a SPOL s.r.o. engineers to PAM-STAMP 2G and demonstrated its potential. Furthermore, they began training two ŠVEC a SPOL s.r.o. employees.

At first with the guidance of ESI engineers, and later on their own, ŠVEC a SPOL s.r.o. started to deal with the problematic drawing operations using PAM-STAMP 2G. ŠVEC a SPOL s.r.o. was surprised by the fact that **the results of simulations were totally identical to the physical pressings**. This is one of the reasons which led them to adopt PAM-STAMP 2G software within their company's production cycle.

*“Since we have started to use PAM-STAMP 2G, we are sure that the development of new tools is correct. If there are no traces of tearing or folding when simulating the process, also no traces of these violations are seen in the shop.”*

Andrej DRIENOVSKÝ,  
Chief Engineer of Stamping  
and Forming Simulation Processes,  
ŠVEC a SPOL s.r.o.

Eventually, ŠVEC a SPOL s.r.o. resolved all the problems they were having with the part and supplied their customer with complete tools ready for serial production. The result was such that two years later ŠKODA chose them again to produce the new generation of the same component. The geometry of the part was modified but still involved a difficult deep-drawing. Geometry verified by simulations was directly used for production of new serial tools. When performing physical tests, no further geometry modifications were needed: everything was functioning immediately, exactly according to the performed simulations. Better yet, the problem with drawing molding of two parts at the same time in the first drawing operation was solved, meaning financial savings for their customer.

Thanks to the precise results of the simulations, ŠVEC a SPOL s.r.o. was able to complete this order successfully in a relatively shorter time period (4 instead of 14 months) and with higher quality than they had been able to do when preparing the first generation of this part, all without a single physical prototype.

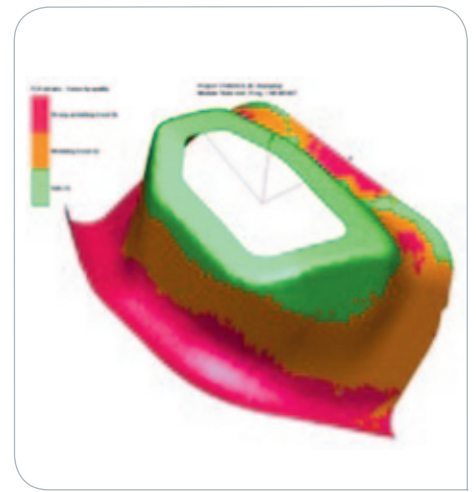

Wheelhouse Component  
as simulated with PAM-STAMP 2G

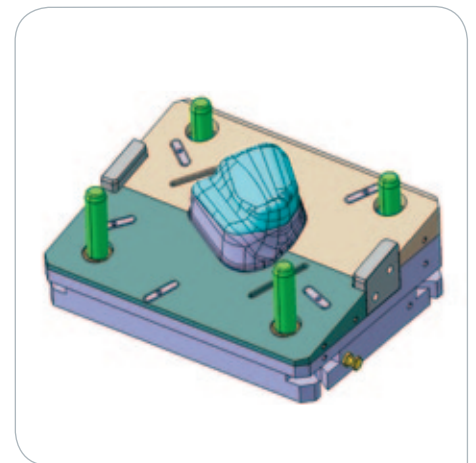

Screenshot of wheelhouse tools  
as simulated with PAM-STAMP 2G

## ABOUT SVEC A SPOL S.R.O.

The company SVEC a spol. s.r.o. was founded in 1993. It is a private company. It resides in Vrable, the region of Nitra, Slovakia. The company's mission is to be the guarantee of professional solutions for customers and to create certainties for its employees. Since its foundation the company has operated in the field of the engineering industry and deals with production of special tools, single-piece and small-lot production, production of iron constructions for the building industry and also production of mechanical typewriters for blind and weak-eyed people. These activities are divided among 3 operations; one of them is a tool factory. It is concerned with development, design and production of tools. In the beginning the company had 15 employees; while today it has 200 employees. Within the first year of business the company attained a turnover of 166.000 EUR. In 2008 it was 10 million EUR. The company SVEC a spol s.r.o. is a holder of the quality certificate ISO 9001:2008.

## ABOUT ESI GROUP

ESI is a pioneer and world-leading provider in virtual prototyping that takes into account the physics of materials. ESI has developed an extensive suite of coherent, industry-oriented applications to realistically simulate a product's behavior during testing, to fine-tune manufacturing processes in accordance with desired product performance, and to evaluate the environment's impact on performance. ESI's solutions fit into a single collaborative and open environment for End-to-End Virtual Prototyping, thus eliminating the need for physical prototypes during product development. The company employs over 800 high-level specialists worldwide covering more than 30 countries.



ESI Group Headquarters | 100-102 Avenue de Suffren | 75015 Paris | FRANCE | T. +33 (0)1 53 65 14 14 | F. +33 (0)1 53 65 14 12 | [info@esi-group.com](mailto:info@esi-group.com)